

*G. Dryden,*  
*Boring Wood.*  
*N<sup>o</sup> 79,640.      Patented July 7, 1868.*

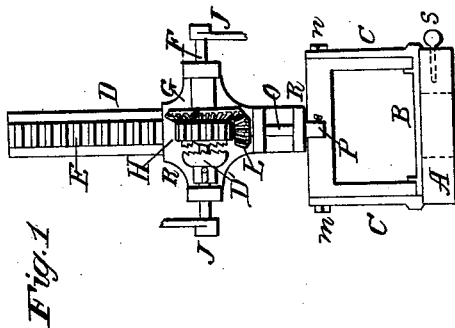
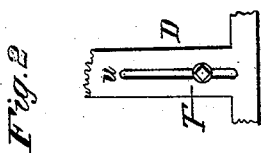

*Witnesses:*

*A. Adams*  
 *Jas. G. Arnold*

*Inventor:*

*George Dryden*

# United States Patent Office.

GEORGE DRYDEN, OF WORCESTER, MASSACHUSETTS.

Letters Patent No. 79,640, dated July 7, 1868.

## IMPROVEMENT IN MACHINES FOR BORING WOOD.

The Schedule referred to in these Letters Patent and making part of the same.

### TO ALL WHOM IT MAY CONCERN:

Be it known that I, GEORGE DRYDEN, of Worcester, in the county of Worcester, and State of Massachusetts, have invented certain new and useful Improvements in Boring-Machines; and I do hereby declare the following to be a full, clear, and exact description of the same, due reference being had to the accompanying drawings, making part of this specification, in which—

Figure 1 shows a front view of my invention.

Figure 2 shows a part of the back, with the adjustable stop and its groove.

The same letters indicate the same parts where they occur.

My invention relates to those boring-machines used for boring for mortises and similar purposes, and consists in pivoting the mechanism that drives the auger to a plate or frame sliding on the base of the machine, and operated by a rack and pinion to adjust it for boring the different holes successively, and also in arranging a central elevating-gear permanently in mesh, with a stationary rack attached to the standard, with such form and construction of parts as to make a convenient and effective boring-machine.

In the drawings, A is the base; D, the standard, forked and pivoted to the plate B, sliding on the base, A. The plate B is operated by a pinion on the shaft S, which meshes into a rack on the under side of B. C C are the arches or ways to adjust the machine to bore any desired angle. O, the mandrel, with a socket at its lower end, P, to hold the auger, the other provided with a bevel-gear, L, by which it is driven, and is supported in the frame R R, which slides on the standard D, and carries a cross-shaft, F, with crank at each end, and a loose spur-gear, H, in the middle, over the mandrel, working into the rack E on the standard D, and a bevel-gear, G, to give motion to the one on the mandrel. i is a clutch, sliding on the shaft F, and driving the spur-gear H when slid up to it. m n is a bolt and nut, to secure the standard in the position desired by fastening it to the ways.

In fig. 2 is shown the back of the lower part of the standard D, and a groove, u, in which slides the adjustable stop T, situated below the frame, and stopping it stops the auger from cutting any deeper than desired, and the operator then sliding the clutch i into the gear H, and continuing the motion of the shaft F, the gear and rack elevate the frame R and withdraw the auger.

The gear H, being over the centre of the auger, draws straight up, without canting against one side, as is the case in the common form of construction.

The other parts may be of the usual forms, and it is therefore deemed unnecessary to describe them more minutely here, and the operation is plain from the above.

I am aware that gear sliding in and out of a stationary rack have been used, and also that the rack has been made movable; these I do not claim; but

What I claim, and desire to secure by Letters Patent, is—

1. The connecting of the driving and carrying-mechanism to a sliding plate or frame moving on the base by means of a rack and pinion, for the purpose of boring the holes of mortises successively, as above set forth.
2. The central elevating-gear, when permanently in mesh with a stationary rack attached to a standard, and operated by a sliding clutch, substantially as set forth and described.

GEORGE DRYDEN.

Witnesses:

A. DADMUN,

JAS. G. ARNOLD.